

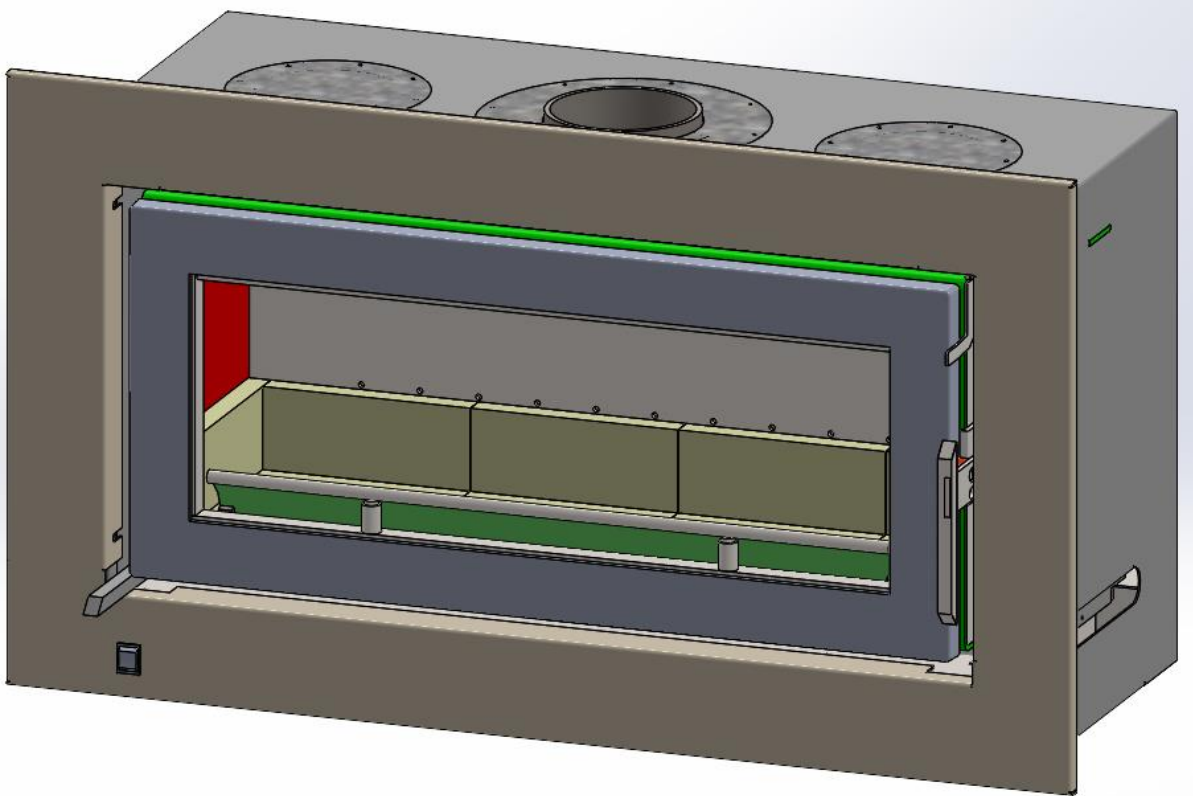

Specialists in fireplace design and manufacture

## **CELESTIAL 900 SOFTWOOD WITH FAN** **INSTALLATION & OPERATING INSTRUCTIONS**



### **IMPORTANT:**

**INSTALLER, PLEASE LEAVE THESE INSTRUCTIONS WITH THE UNIT ON COMPLETION.**

## **10 YEAR FIREBOX WARRANTY**

**The firebox is covered by a 10 year warranty.  
Other parts are covered by a one year limited warranty.**

Head Office - 13 French Avenue, Brendale, Queensland 4500

Telephone - PH: (07) 3490 5500

Facsimile - FAX: (07) 3490 5520

Website - [www.jetmaster.com.au](http://www.jetmaster.com.au)

Business hours - Monday to Thursday 7:30am-4:00pm. Friday 7:30am-2:00pm

Email - [sales@jetmaster.com.au](mailto:sales@jetmaster.com.au)

# DIMENSIONS

## CELESTIAL 900 WITH FAN AND HEAT DUCTING BOX FOR MASONRY / HEBEL

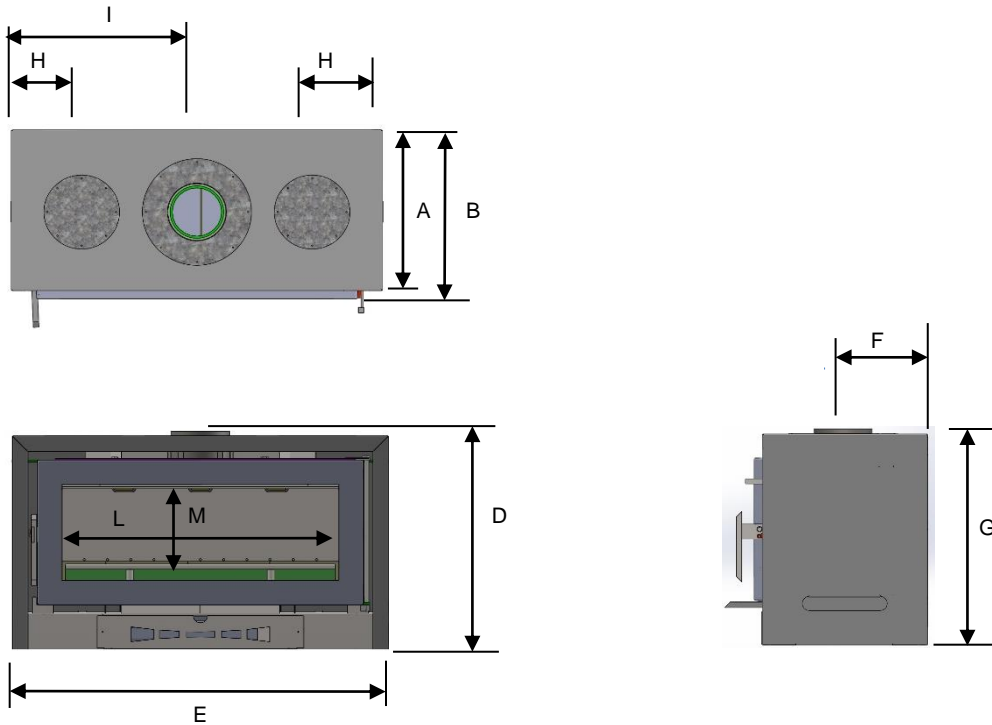

### FASCIA

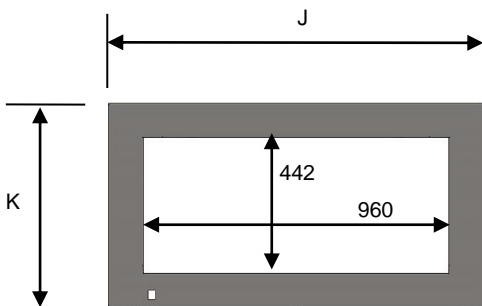

| DESC.         | MODEL       | A   | B   | C | D   | E    | F   | G   | H   | I   | J    | K   | L   | M   |
|---------------|-------------|-----|-----|---|-----|------|-----|-----|-----|-----|------|-----|-----|-----|
| CELESTIAL 900 | WALL INSERT | 468 | 495 | - | 608 | 1054 | 252 | 610 | 202 | 528 | 1180 | 662 | 776 | 268 |

# HEARTH MEASUREMENT

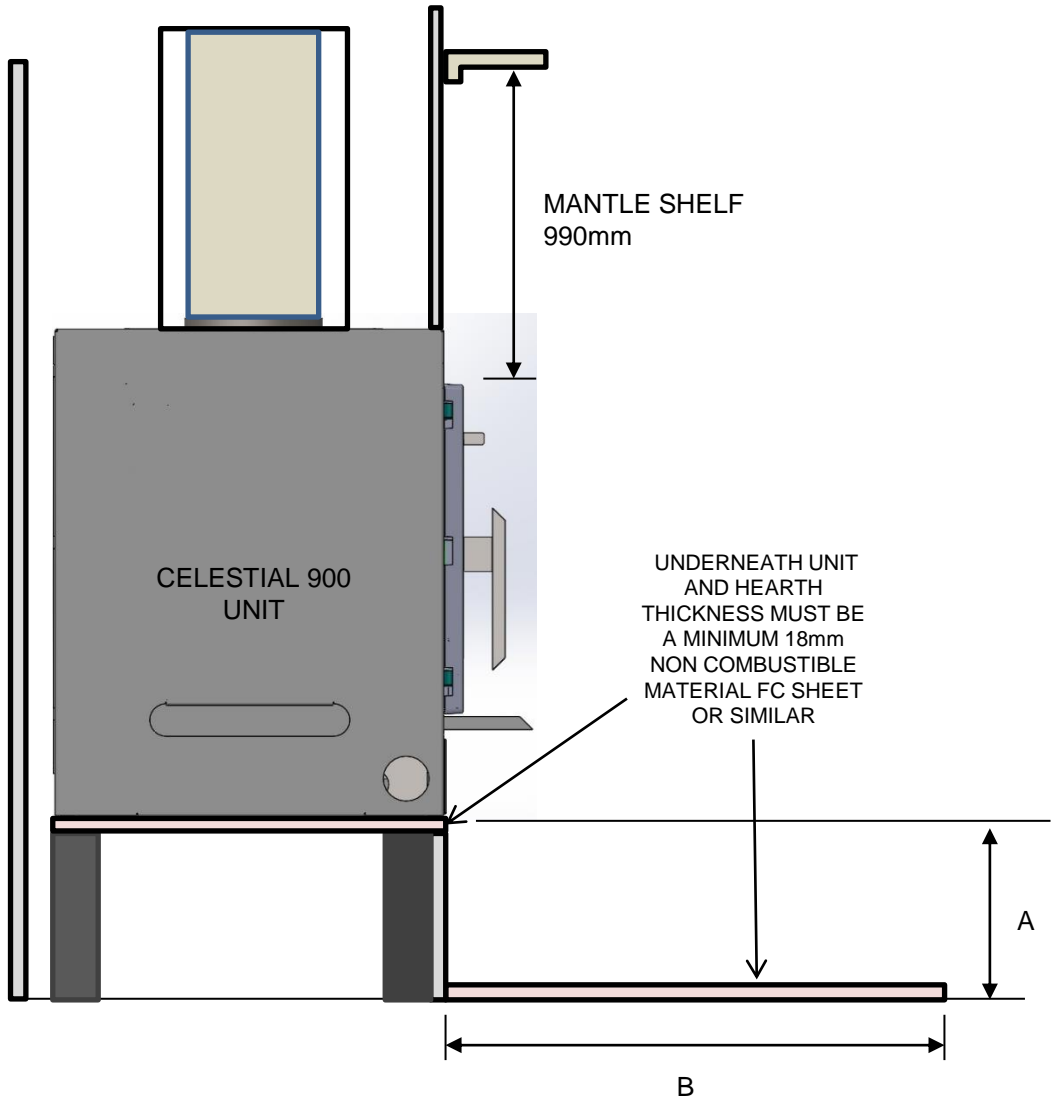

|    |                                  |     |
|----|----------------------------------|-----|
| A. | UNIT HEIGHT ABOVE FLOOR          | 200 |
| B. | HEARTH DIMENSION FORWARD OF UNIT | 530 |

# HEARTH REQUIREMENTS FOR INSTALLATION ONTO A RAISED HEARTH

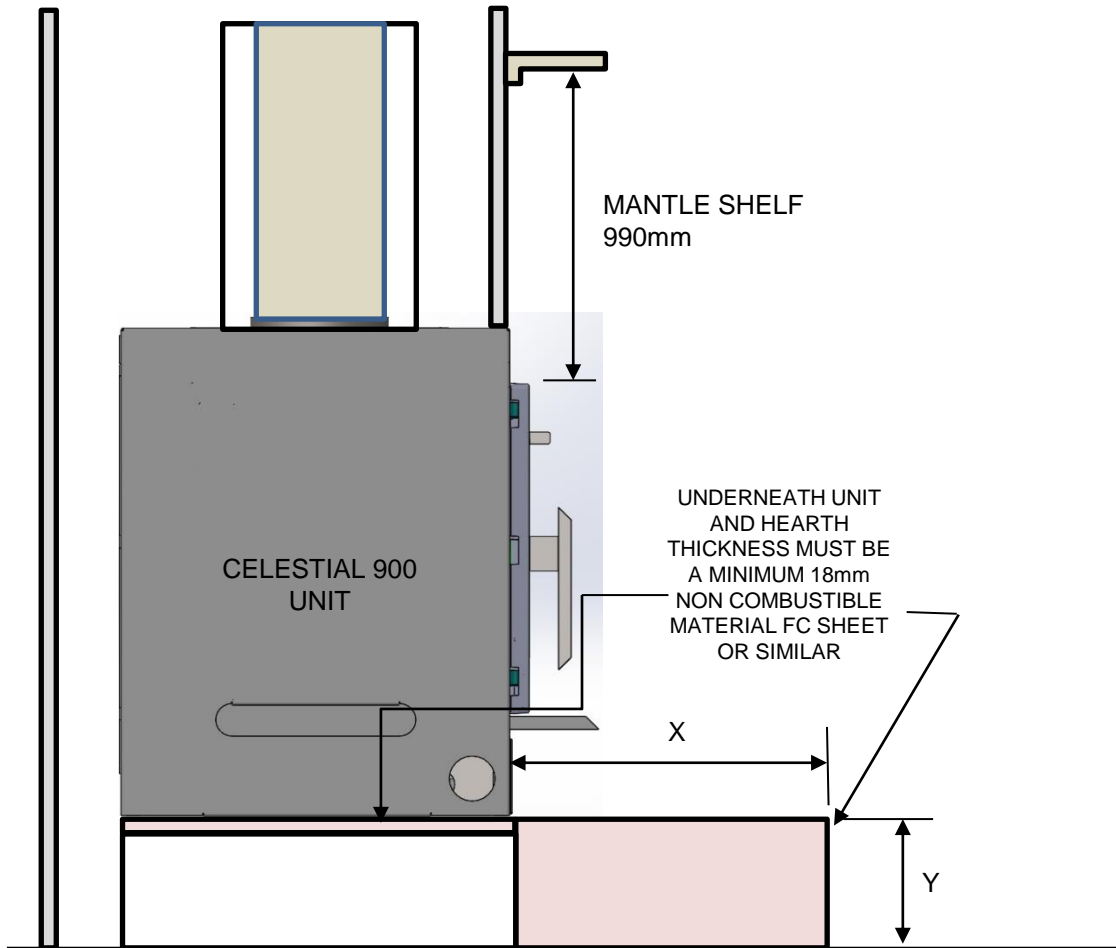

|    |                             |      |
|----|-----------------------------|------|
| X. | MIN. DEPTH MEASUREMENT (mm) | 300  |
| Y. | MIN. HEIGHT INCREASE (mm)   | 200* |

\* NOTE: IF Y IS LESS THAN 200mm THEN REFER TO HEARTH MEASUREMENT ON PREVIOUS PAGE

# **BAFFLE PLATE INSTALLATION**

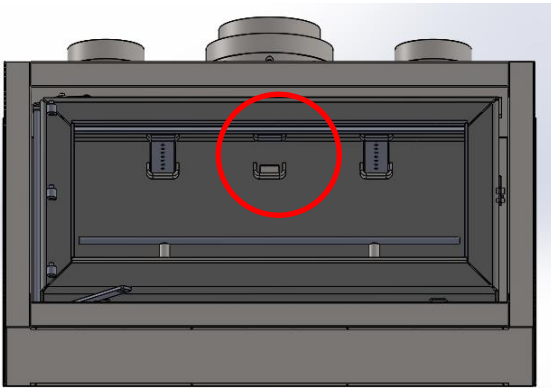

1. REMOVE MIDDLE AIR TUBE BY PUSHING UP AND REMOVING FROM FRONT AND REAR BRACKETS.

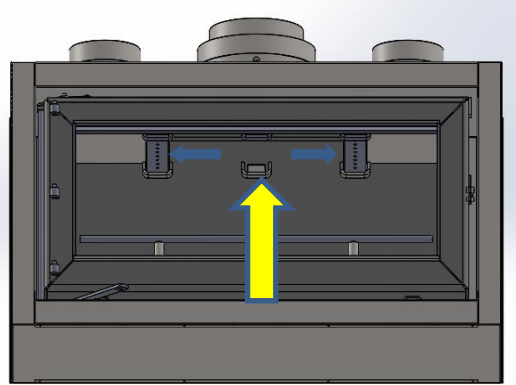

2. PLACE ALL 4 BAFFLE PLATES ABOVE AIR TUBES BOTH SIDES CLOSEST TO THE FIRE BOX WALL AS SHOWN ( 2 LEFT AND 2 RIGHT)

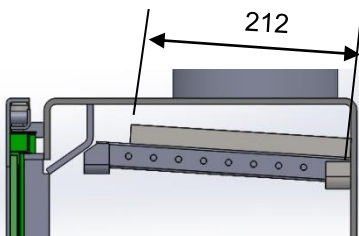

3. PLACE BAFFLE PLATES AS FAR BACK AS POSSIBLE, 212 MM FROM FRONT TO BACK.

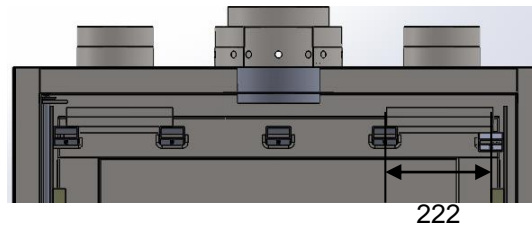

4. BAFFLE PLATE SIDE OF 222 MM SHOULD EXTEND FROM SIDE TO SIDE,

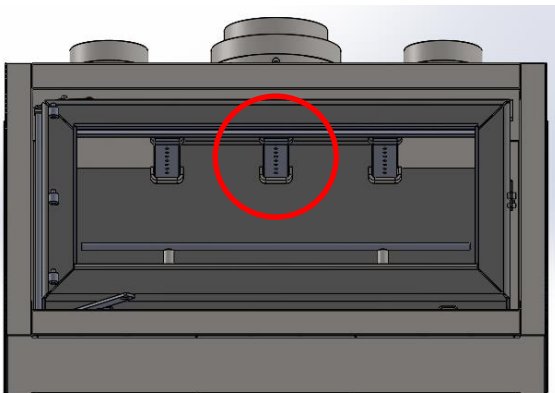

5. RE- PLACE MIDDLE AIR TUBE BACK INTO POSITION  
( NB. MAKE SURE OPEN END OF AIR TUBE IS PLACED INTO REAR OPENING. CLOSED END TOWARDS DOOR. FAILURE TO INSTALL AIR TUBES CORRECTLY WILL VOID WARRANTY.)

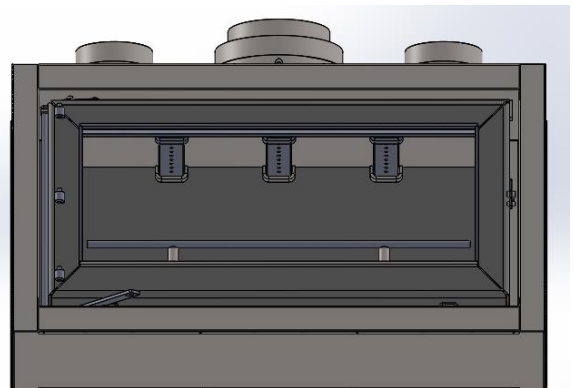

6. SLIDE THE BAFFLE PLATES ATOP THE OTHER 2 BAFFLE PLATES INTO THE MIDDLE POSITION AS SHOWN. LEAVE GAP OF 1-2 MM IN BETWEEN PLATES. THE GAPS SHOULD BE ROUGHLY IN THE MIDDLE OF THE AIR TUBES. UNIT IS NOW READY FOR USE.

# CELESTIAL 900 MASONRY BLOCK CONSTRUCTION

Flue system to be installed  
to suit AS/NZS 2918.2001

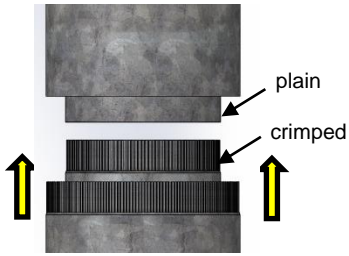

All 8"-10" assembled flues must have the crimps pointing upwards

DETAIL A

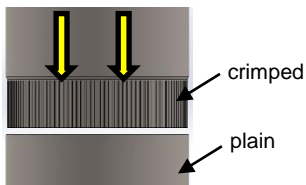

All 6" assembled flues must have the crimps pointing downwards

DETAIL B

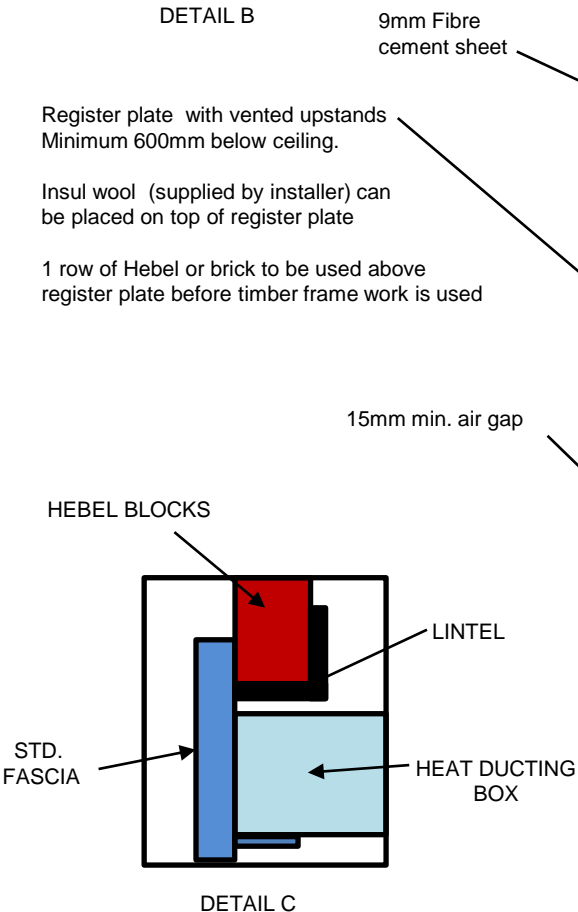

DETAIL C

Triple skin flue system  
(10", 8" and 6")

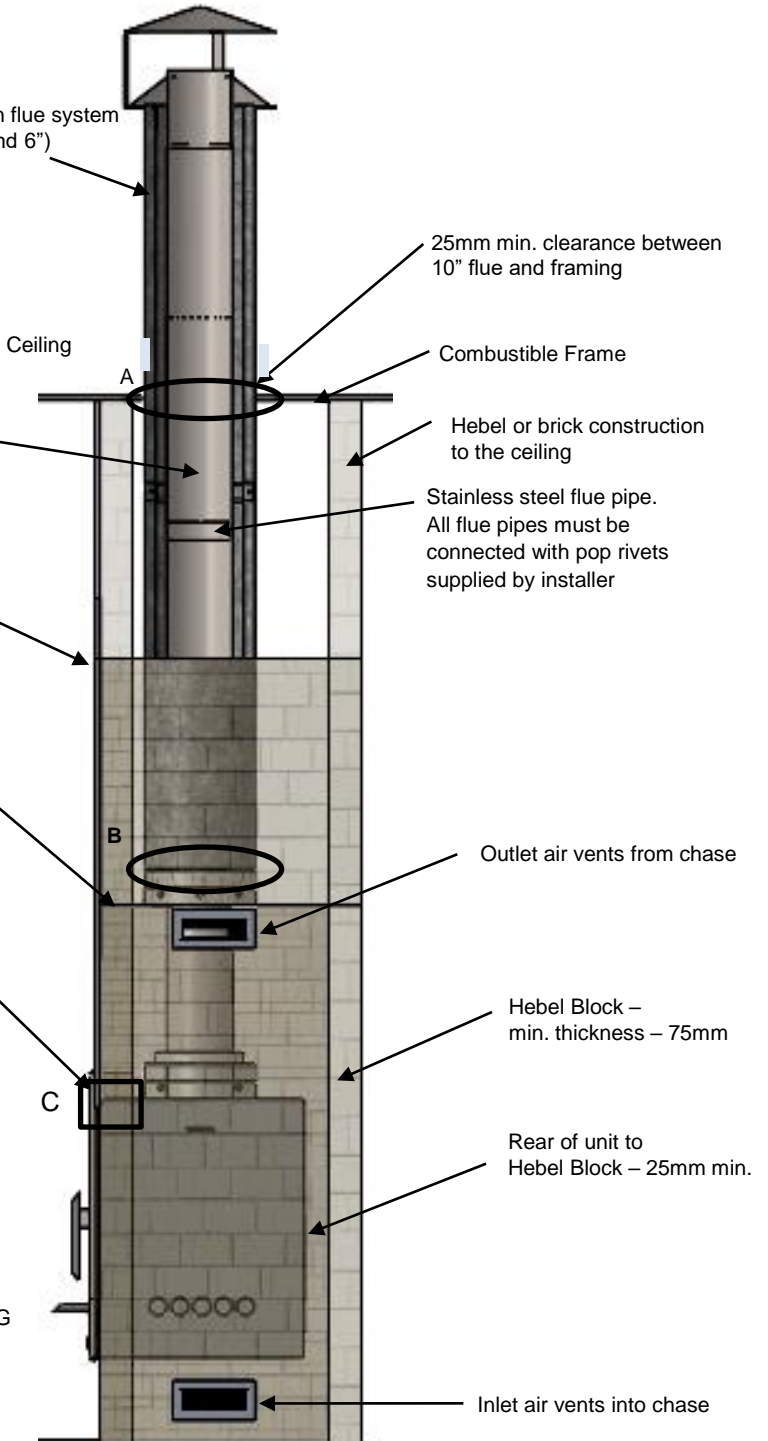

25mm min. clearance between  
10" flue and framing

Ceiling

Combustible Frame

Hebel or brick construction  
to the ceiling

6" Flue

Stainless steel flue pipe.  
All flue pipes must be  
connected with pop rivets  
supplied by installer

9mm Fibre  
cement sheet

Register plate with vented upstands  
Minimum 600mm below ceiling.

Insul wool (supplied by installer)  
can be placed on top of register plate

1 row of Hebel or brick to be used above  
register plate before timber frame work is used

Outlet air vents from chase

15mm min. air gap

Hebel Block -  
min. thickness - 75mm

Rear of unit to  
Hebel Block - 25mm min.

Inlet air vents into chase

## **ACTIVE FLUE INSTALLATION**

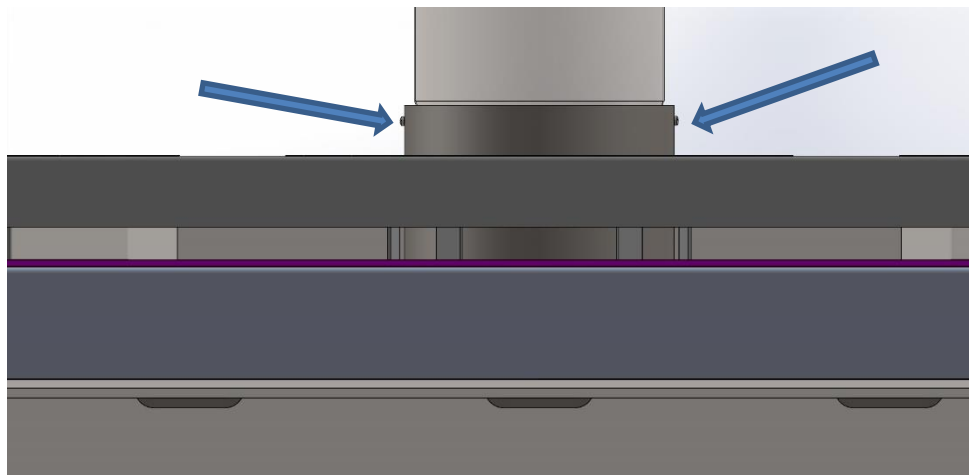

### **NOTE:**

The active flue must either be screwed on or riveted to the spigot by the installer in order to stop movement or disassembly.

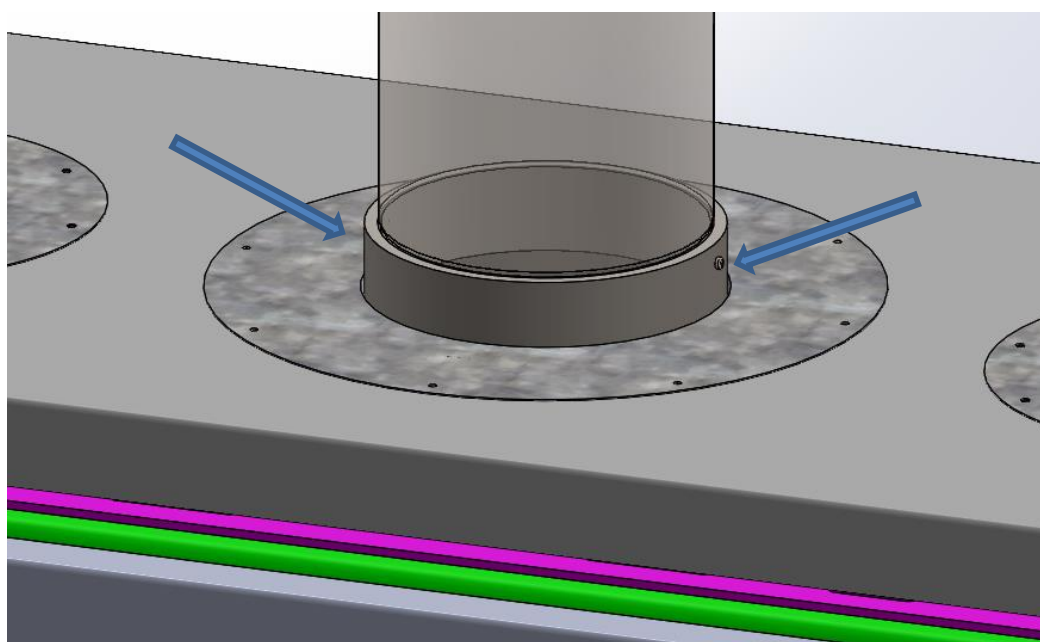

# CELESTIAL 900 MASONRY BLOCK CONSTRUCTION

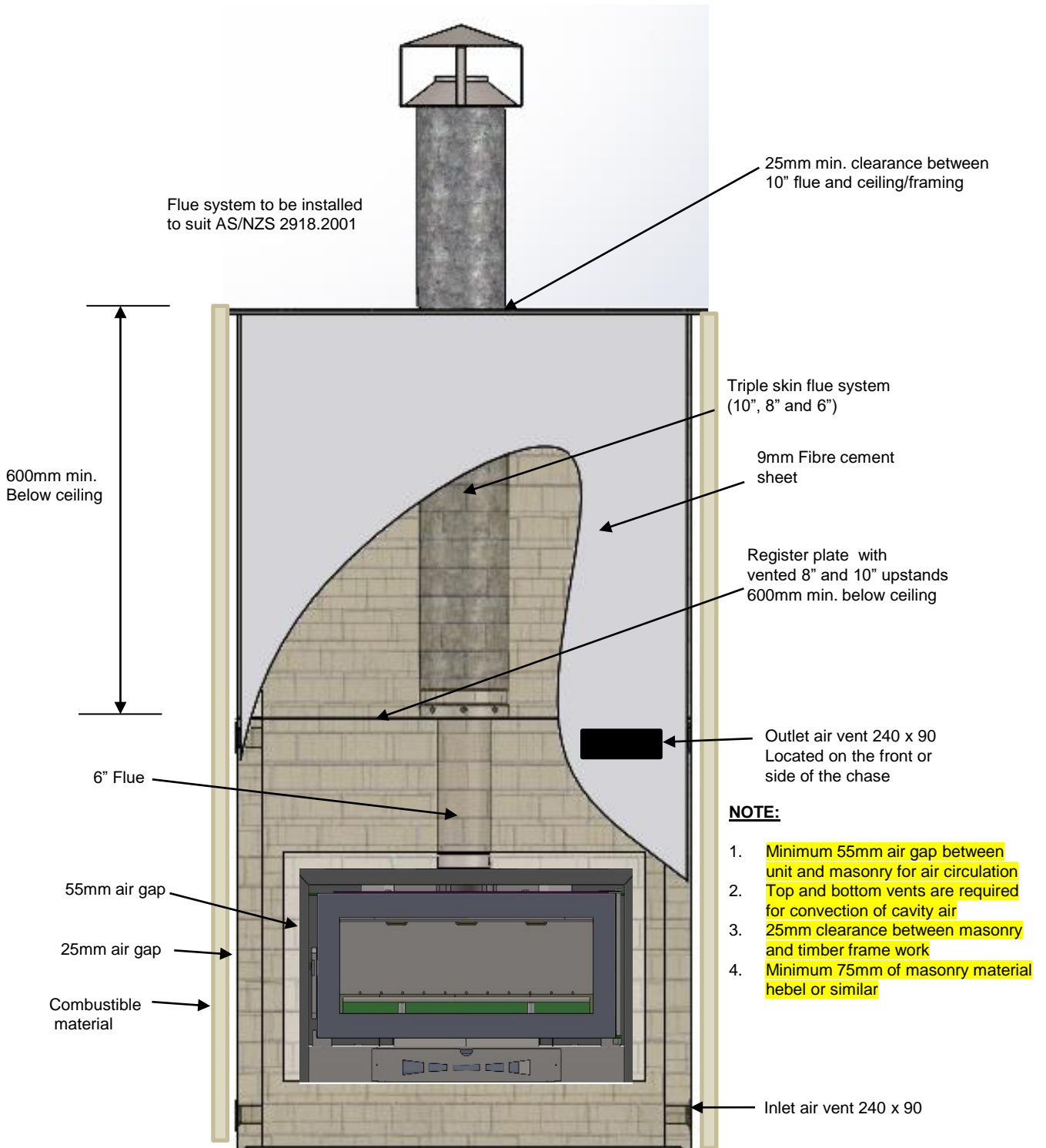



# **CELESTIAL 900 MASONRY** **OPENING CUT SIZE**

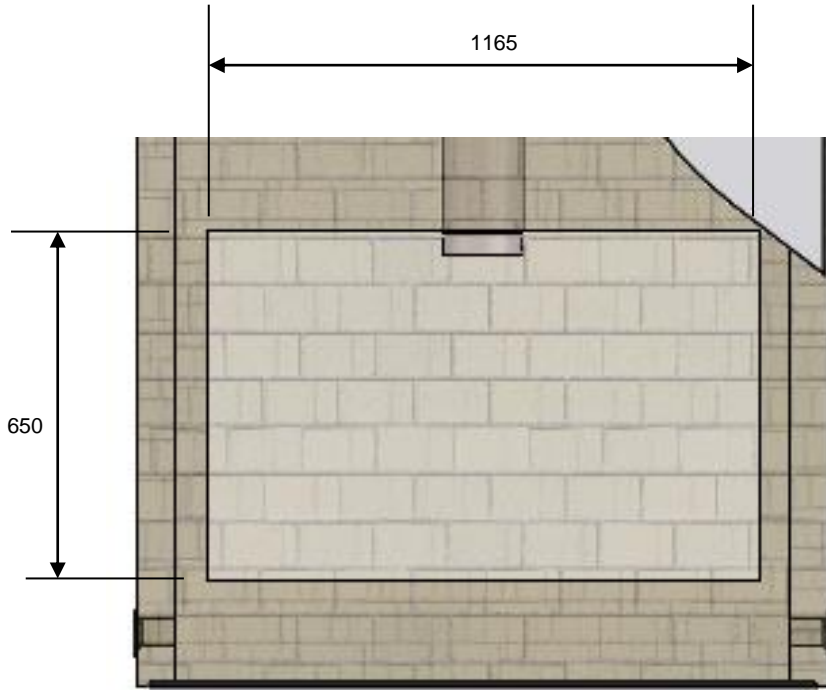

**NOTE:**

THE APPLIANCE WILL NEED 505mm DEEP OPENING TO THE BACK OF CHASE

# PYROTEK ZERO CLEARANCE INSTALLATION

## TOP VIEW

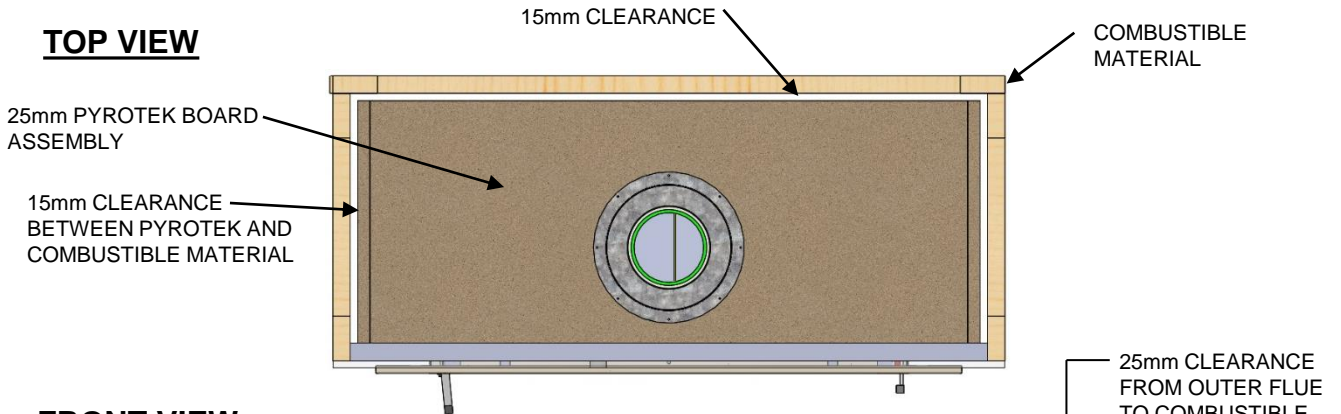

## FRONT VIEW

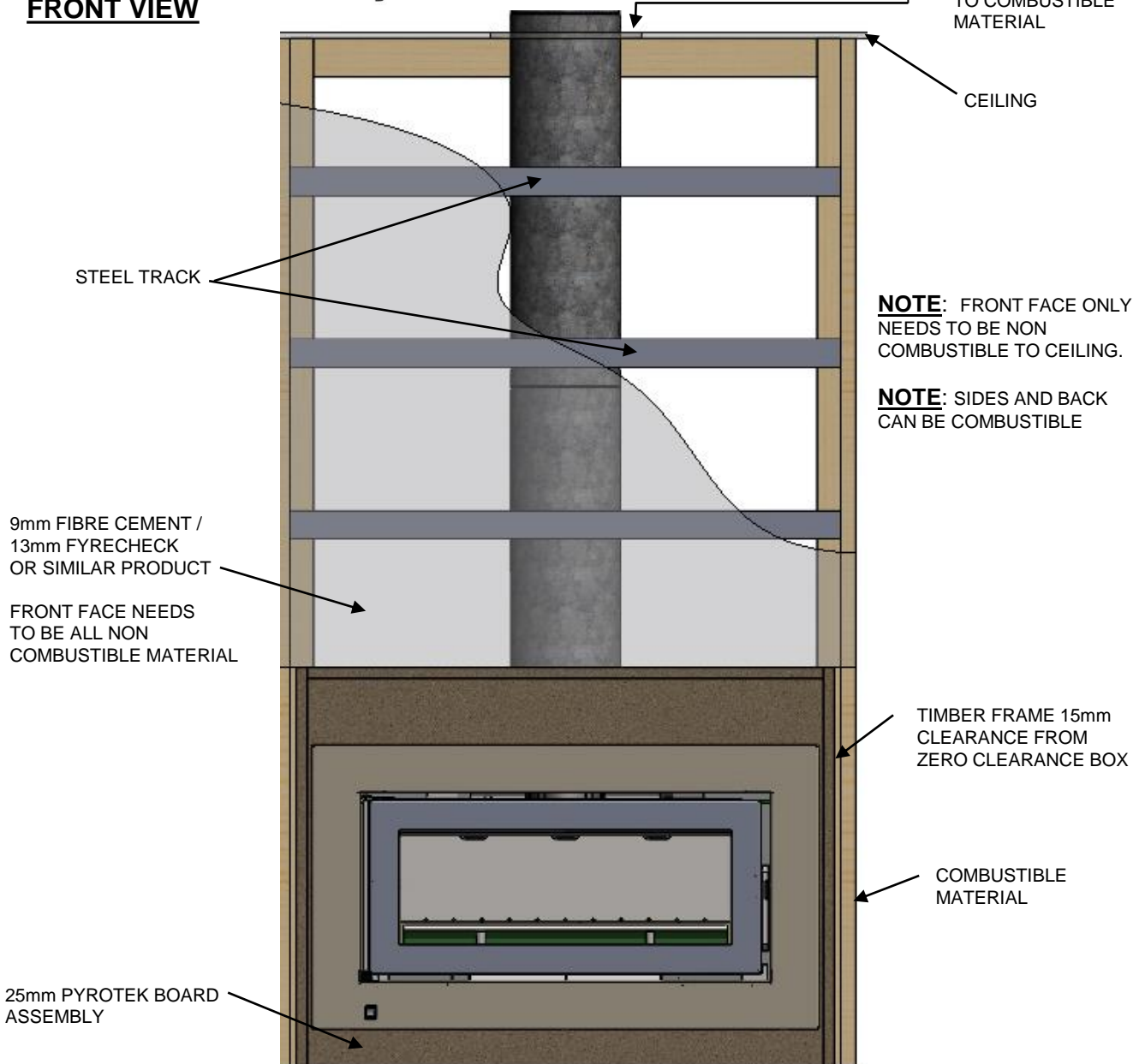

# **DIMENSIONS FOR WHITE BOARD ZERO CLEARANCE BOX**

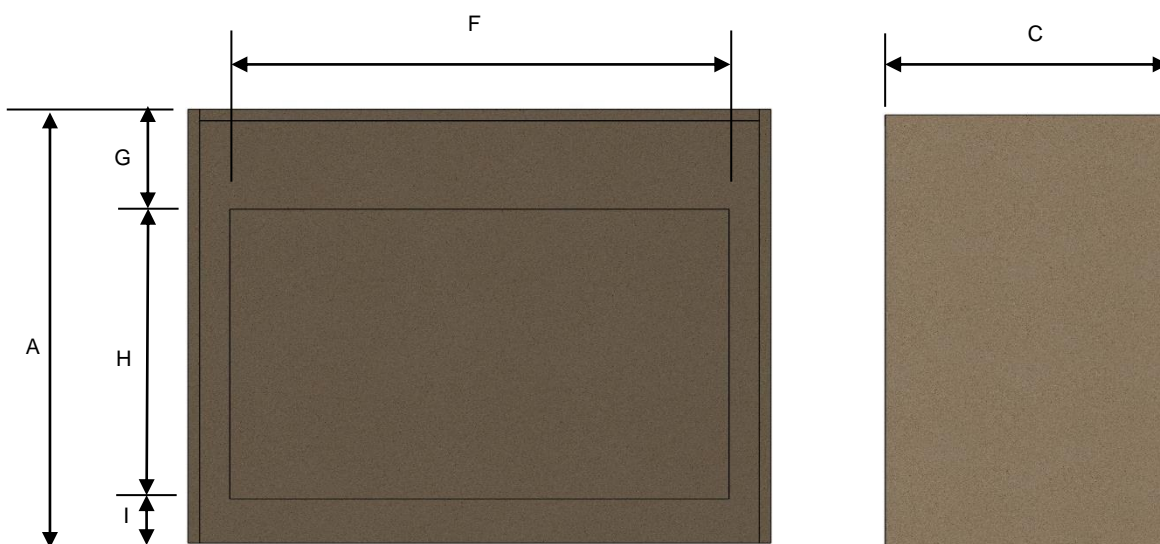
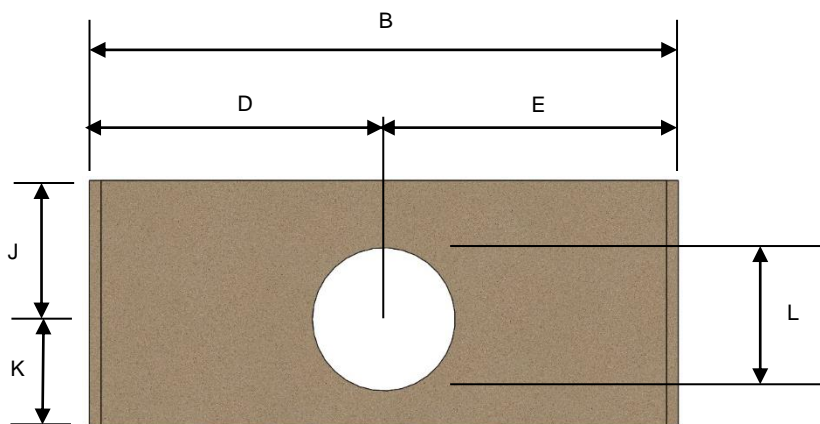

|                        | A   | B    | C   | D   | E   | F    | G   | H   | I  | J   | K   | L   |
|------------------------|-----|------|-----|-----|-----|------|-----|-----|----|-----|-----|-----|
| CELESTIAL 900 WITH FAN | 933 | 1254 | 523 | 626 | 626 | 1073 | 215 | 623 | 95 | 295 | 228 | 304 |

# **CELESTIAL 900 FASCIA INSTALLATION INFORMATION**

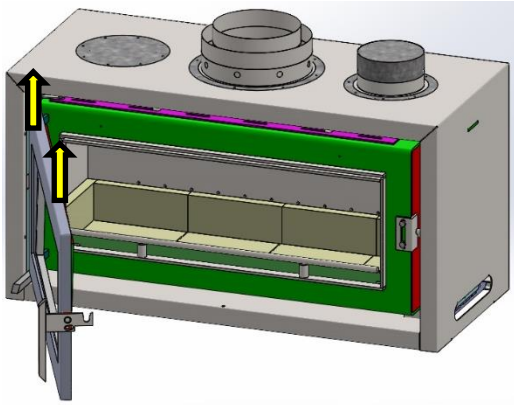

1. OPEN THE DOOR TO ABOUT 70 DEGREES TO THE FRONT OF THE FIREBOX. LIFT THE DOOR UPWARDS UNTIL THE DOOR CLEARS THE HINGES AND MOVE IT OUT OF THE WAY.

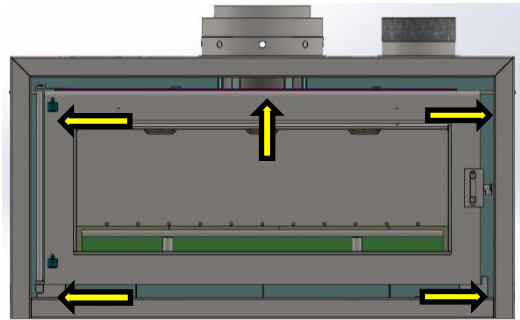

2. THREAD ONE SCREW AND ONE WASHER (SUPPLIED) TO EVERY NUT SERT SHOWN. MAKE SURE THE WASHER IS AS CLOSE TO THE SCREW HEAD AS POSSIBLE. LEAVE ENOUGH GAP FOR THE FASCIA TO SLIDE BETWEEN THE BOX AND THE WASHER.

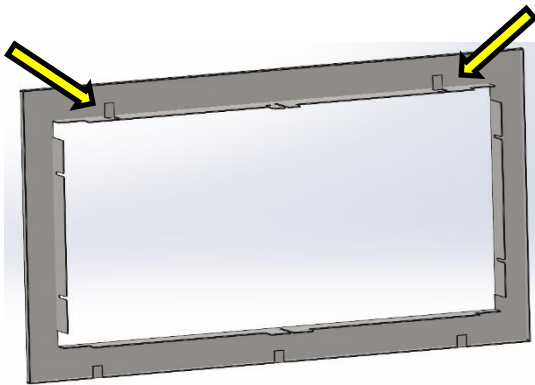

3. BEND THE SILICONE TABS INTO POSITION. THIS TAB SHOULD BE PARALLEL TO THE FRONT OF THE FASCIA WHEN IN THE CORRECT POSITION.

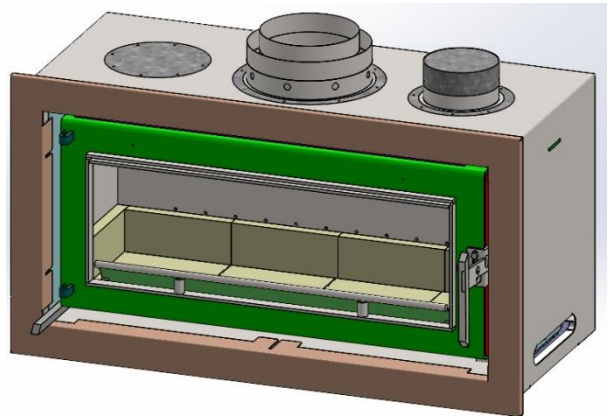

4. SLIDE FASCIA INTO THE REQUIRED POSITION THEN HAND TIGHTEN THE SCREWS AS REQUIRED OR USE AN APPROPRIATE ALLEN KEY OR PLIERS. USE A TOUCH UP PAINT ON THE SCREW HEADS AS REQUIRED.

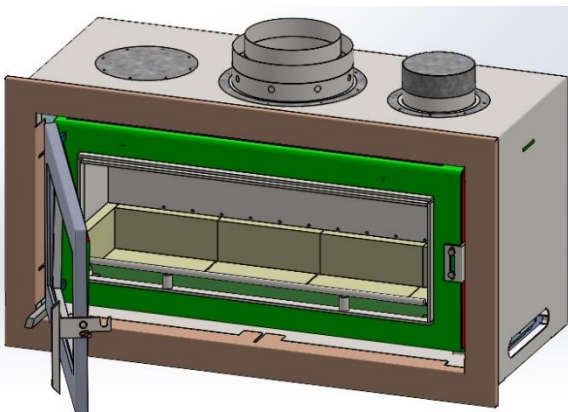

5. RE INSTALL THE DOOR BACK ON. USE THE REVERSE METHOD TO REMOVAL ON POINT 1.

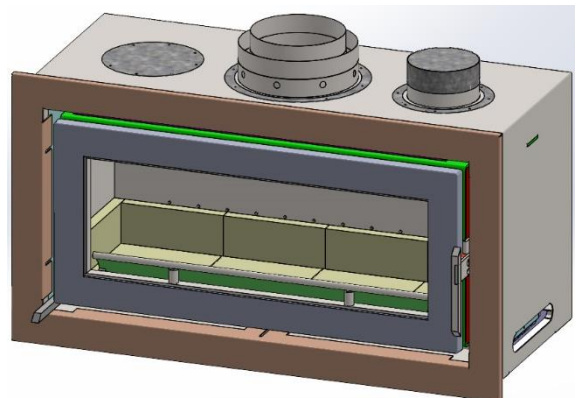

6. DOUBLE CHECK TO MAKE SURE THE DOOR CLOSSES PROPERLY AND DOES NOT TOUCH THE FASCIA. THE INSTALLATION SHOULD BE COMPLETE.

# **CELESTIAL 900 WITH FAN** **DOOR ADJUSTMENT INFORMATION**

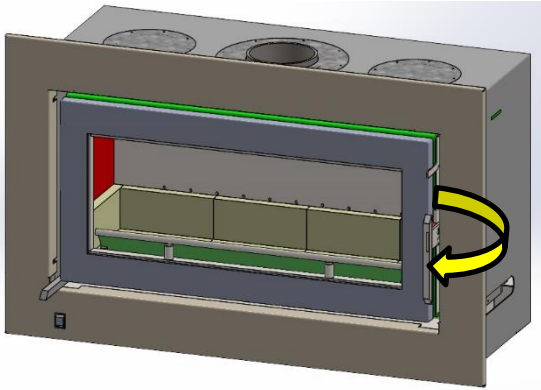

1. OPEN THE DOOR AS FAR AS REQUIRED, AND THE ADJUSTMENT ANGLE IS ACCESSIBLE.

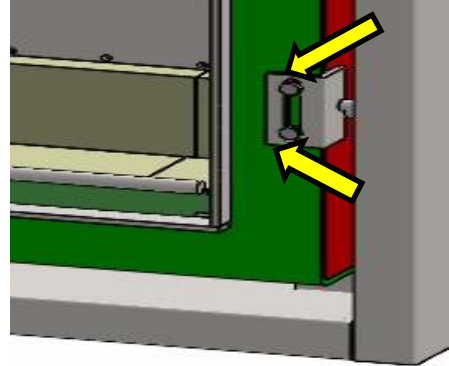

2. MARK THE POSITION OF THE ADJUSTMENT ANGLE ON THE FIREBOX. IT IS CRITICAL TO PUT THE ADJUSTMENT ANGLE AT THE SAME SPOT. SO THAT THE DOOR WILL LOCK PROPERLY.

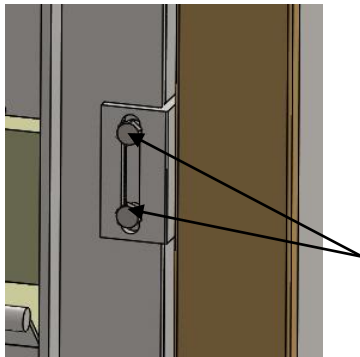

3. LOOSEN THE 2 BOLTS AS REQUIRED. DO NOT UNSCREW THE BOLTS ALL THE WAY OUT.

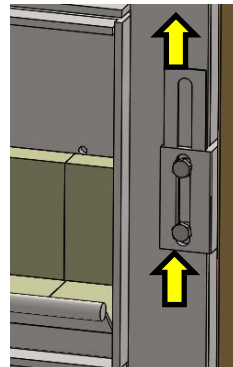

4. PUSH THE PACKER FROM THE BOTTOM EDGE OF THE ADJUSTMENT ANGLE UNTIL FULLY REMOVED. ONLY TAKE OUT WHAT IS NECESSARY. RE-POSITION THE ADJUSTMENT ANGLE AT THE MARKERS AND TIGHTEN.

**NOTE:** UP TO 4 PACKERS CAN BE REMOVED IF NECESSARY.

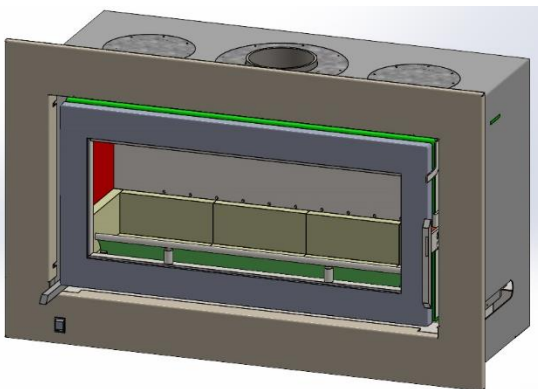

5. CLOSE THE DOOR AND CHECK IF THE LATCH LOCKS PROPERLY, THE ADJUSTMENT IS COMPLETE IF NO ADJUSTMENT IS NEEDED.



# **CELESTIAL 900 WITH FAN REMOVAL / INSTALLATION**

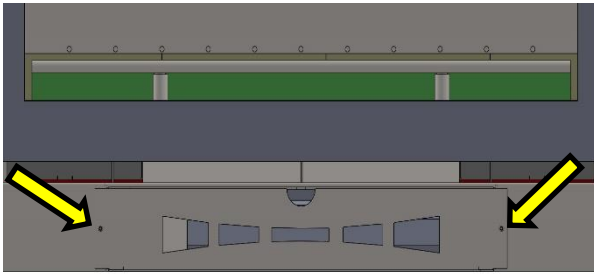

1. REMOVE 2 SCREWS HOLDING THE FAN CASSETTE IN PLACE

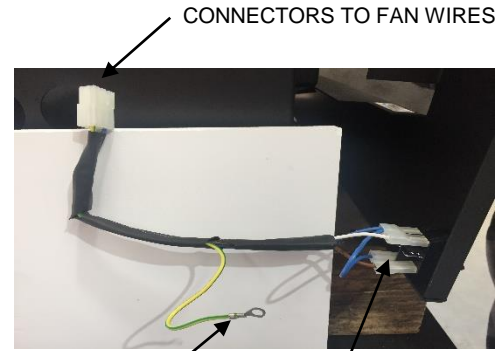

2. UNPLUG THE FAN CONNECTOR FROM THE FASCIA CONNECTOR, UNSCREW THE EARTH WIRE FROM THE APPLIANCE . REMOVE THE FASCIA

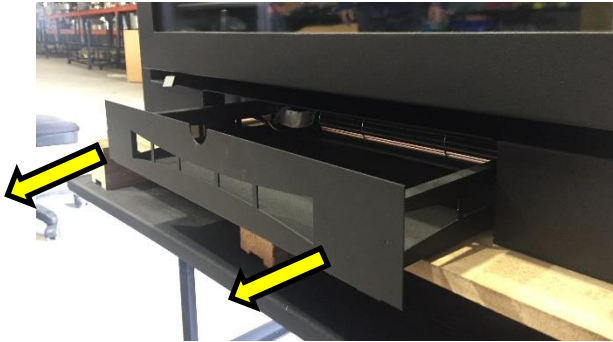

3. PULL THE FAN CASSETTE AWAY FROM THE APPLIANCE, ABOUT HALFWAY OUT, THEN GENTLY PULL THE FAN WIRE LOOMS BACK INTO THE FAN CASSETTE.



4. CONTINUE PULLING THE FAN CASSETTE OUT AND TILT UP THE FRONT EDGE OF THE FAN CASSETTE AT THE LAST MOMENT TO RELEASE IT FROM THE APPLIANCE CAVITY



5. PULL FAN CASSETTE AWAY FROM THE APPLIANCE.TAKE NOTE OF THE FAN POSITION WHILST STILL IN THE CASSETTE. THIS WILL BE IMPORTANT DURING RE-INSTALLATION.

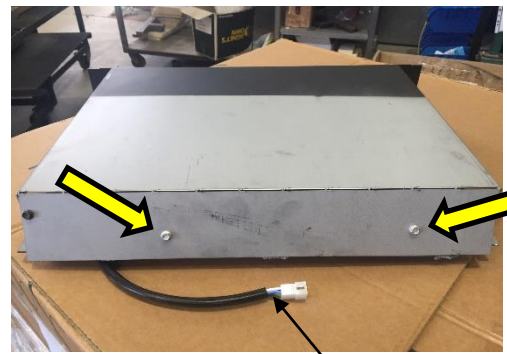

6. USE A FLAT SURFACE AND LAY THE FAN CASSETTE UPSIDE DOWN. REMOVE THE 2 SCREWS HOLDING THE FAN ASSEMBLY. THE FAN SHOULD NOW BE FREE. REPLACE THE FAN AS REQUIRED IN THE ORIGINAL POSITION INSTALLATION IS JUST THE REVERSAL OF THE STEPS OUTLINED

# CELESTIAL 900 WITH FAN FAN SWITCH ELECTRICAL INSTALLATION

**IMPORTANT: THIS WORK MUST BE PERFORMED BY A QUALIFIED INSTALLER**



GREEN / YELLOW  
(GROUND WIRE)

1

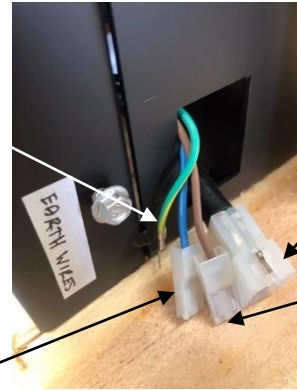

FAN  
CONNECTOR

BROWN  
WIRE  
(ACTIVE)

3

2 BLUE  
WIRE  
(NEUTRAL)

1. PUSH EXTERNAL POWER CORD THROUGH THE ROUND HOLE CUT OUT

2. SAME CORDS NEEDS TO EXIT THROUGH THE FRONT OF THE FIREBOX VIA THE RECTANGULAR CUT OUT

## FAN SWITCH WIRING LOOM

BLUE  
WIRE  
(NEUTRAL)

4A

BROWN  
WIRE  
(ACTIVE)

5

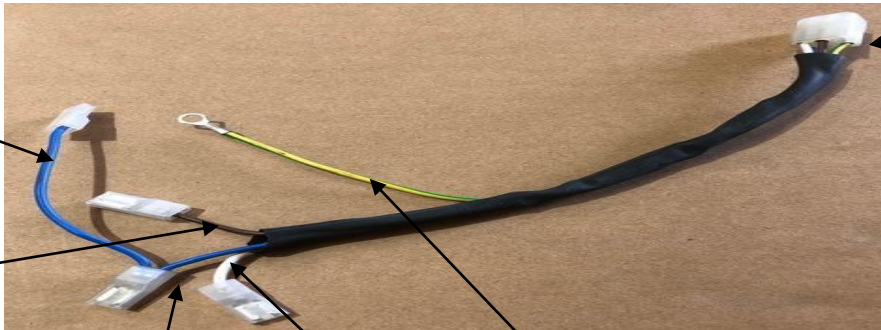

CONNECTOR

BLUE  
WIRE  
(NEUTRAL)

4

WHITE  
WIRE

6

GREEN / YELLOW  
(GROUND WIRE)

7

GROUND WIRE  
FROM EXTERNAL  
POWER CORD

1

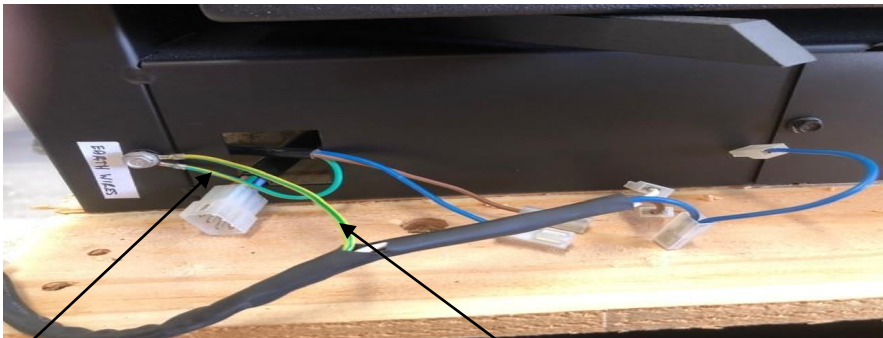

GROUND WIRE FROM  
FAN SWITCH WIRING LOOM

7

3. USE THE SELF TAPPING SCREW AS ATTACHED AND LABELLED FOR GROUND WIRES, SCREW BOTH GROUND WIRES FROM THE EXTERNAL POWER CORD AND FAN SWITCH WIRING LOOM AS SUPPLIED.

# **CELESTIAL 900 WITH FAN** **FAN SWITCH ELECTRICAL INSTALLATION**

**IMPORTANT: THIS WORK MUST BE PERFORMED BY A QUALIFIED INSTALLER**

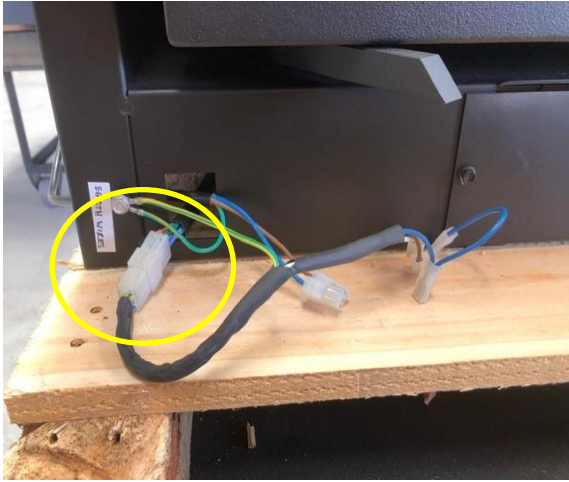

4. PLUG THE FAN SWITCH WIRING LOOM CONNECTOR TO THE FAN CONNECTOR

5. PLUG IN THE WIRE CONNECTORS TO THE FAN SWITCH, REFER TO DIAGRAM BELOW FOR PLACEMENT (CONNECTED BROWN AND BLUE WIRE SHOWN FROM EXTERNAL POWER CORD)

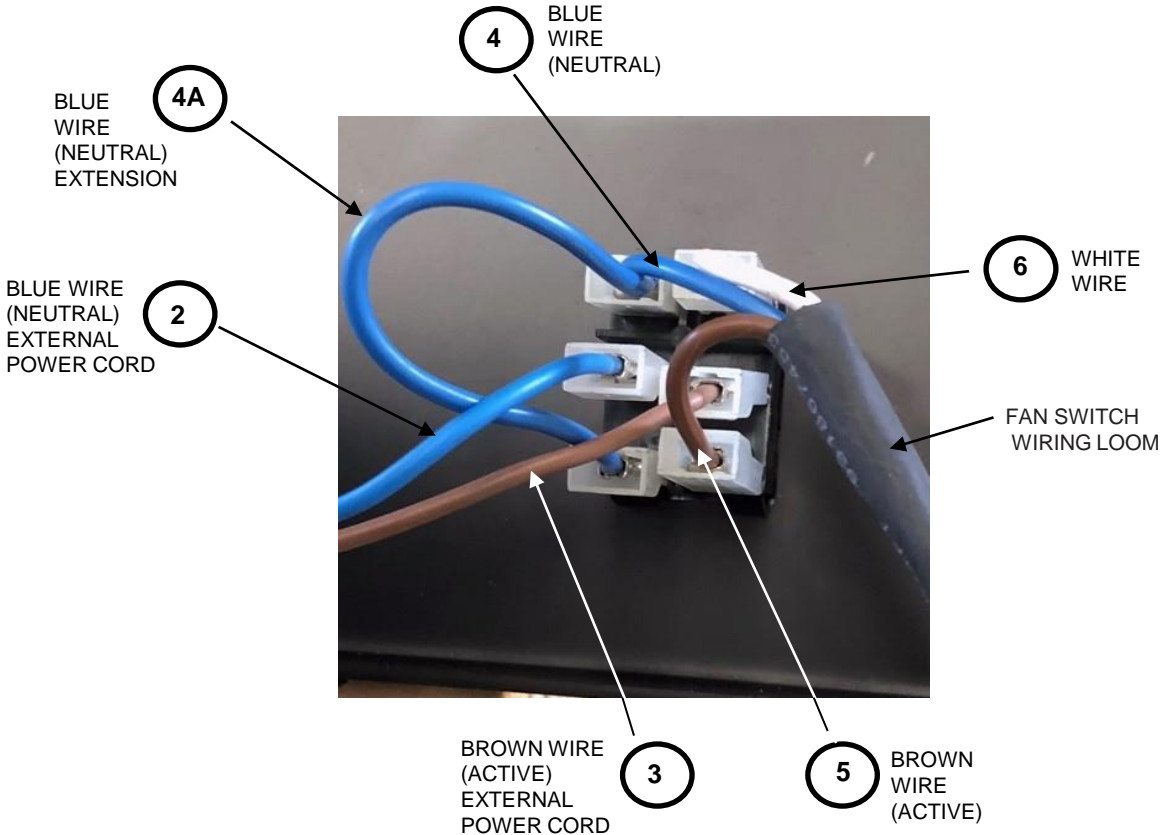

6. WHEN ALL THE CONNECTORS ARE IN PLACE, TURN POWER ON AND TEST, IF THE FAN TURNS ON, THEN THE ASSEMBLY IS COMPLETE.



# CELESTIAL 900 SOFTWOOD BOOST OPERATION

BOOST FLAP, IN  
OPEN POSITION.  
PUSHED TOWARDS  
THE RIGHT AS FAR  
AS POSSIBLE.

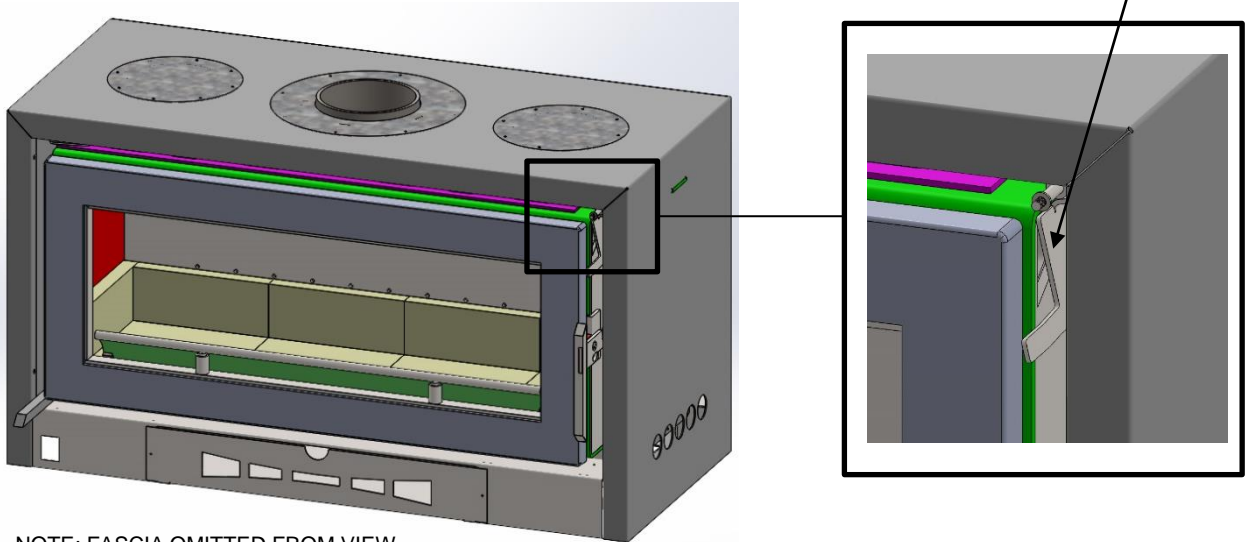

NOTE: FASCIA OMITTED FROM VIEW

## NOTE:

The boost flap need to be left open for the **first 20 minutes** of operation, in order to light the fire better. After this time, normal appliance operation will commence and the boost flap will need to be shut for the duration of use.

# KEMLAN INDUSTRIES

## Operating Instructions

Congratulations on the purchase of your Australian made Kemlan slow combustion wood fireplace.

We hope this serves you well, not just as a stunning feature; but as a functional tool for heating your home and keeping you and your family warm however cold the winters may get, because this is what Kemlan specialises in and has perfected, making fires in Brisbane QLD since 1969, 'Australian made for Australian conditions'.

Welcome to the Kemlan family.

I would like to share with you the correct way to operate your Kemlan wood fire giving best results for both heating and useability.

Let's get started:

### The First Burns -

Unfortunately, we have no control over how the fire is loaded nor do we have any control over what quality of fuel / timber is used, therefore we can only give recommendations, and this will be the difference in heat output and length of burn.

Hard wood should always be used as the main fuel source in all Kemlan wood heaters at a moisture level of between 12% - 20% (always have a moisture meter).

If the timber is too dry it will burn faster, if the timber is too wet it will struggle to burn at all and give very little heat.

The first few burns in a wood fire are commonly referred to as 'curing burns', this is when you are getting heat into the appliances steel and paint for the first time.

### **What we are trying to achieve here is 3-fold:**

The **first** goal is to get heat into the white ceramic baffles and the steel flue system, getting these 2 things hot will create the 'draw' of the fireplace this is the process in which the smoke is drawn out of the fireplace chamber through the flue system.

The **second** goal is to lay a bed of ash in the base of the fire, ash in the bottom of the fire is essential to the performance of the fireplace, the optimal thickness of ash is 2-3 Inches (25mm - 75mm).

Having this bed of ash will assist the fuel to light easier creating an air layer under the timber, it will also assist in a longer hotter burn as the ash holds a large amount of the heat while the timber above is burning. So DO NOT clean your ash out until you have to, you should never see the firebricks in the base of your fire.

The **third** goal of the initial burns is to cure the paint on the fireplace casing, Kemlan fires are painted with a high temperature paint. When first applied at our factory, the paint is very soft, we place all finished fireplaces under heat lamps to start the 'curing' process but because of the time it takes and

the temperature the casing needs to stay at to complete this process we need YOU to finish this cure in your home by lighting your new fire! So, let's do it!.....

### **Building your fire -**

Whether you have purchased a small, medium or large chamber fireplace the set-up is the same.

Kemlan introduce more primary air into the chamber of the fireplace than most other brands on the market, this makes it very easy to light the fire from a cold start, it also makes it easy for you the user of the fireplace to load the paper or firelighters, kindling (small pieces of soft wood) and hard wood into the chamber straight away.

Your goal should be to fill the fireplace chamber front to back, sided to side to make sure heat is evenly distributed throughout the entire firebox.

We don't want to have to keep tending to the fireplace slowly adding pieces of timber and constantly opening the door, one full load of timber is far better.

Scan the QR code below to access the 'How to stack and light your Kemlan wood fire' video.

Please take some time to watch to see if your process is the same.



Now your Kemlan fire is up and running make sure to keep the primary air slide fully open, this will ensure maximum oxygen is getting to the fuel and this will create quicker heat into the fireplace box, baffle, flue and of course your home.

The air slide can move from extreme left (fully open) to extreme right (fully closed).

Think of this slide like an accelerator and brake on a car. Fully open would be putting your foot down on your car's accelerator, fully closed is like putting the breaks on in the car.

When we want energy into the room (KW) we want the slide open, as the room gets to the desired temperature the air slide can be moved towards the right-hand side reducing the air to the chamber slowing the energy output and fuel consumption.

The air slide should only be moved half to  $\frac{3}{4}$  of the way across while you can still tend to the fire, closing it completely or starving the fire should only be done when you cannot tend to the fire for long periods of time (e.g. going to bed) when your only goal is for length of burn.

Remember no matter whether it is a curing burn or an everyday use, heat is key, never light a small fire! A small fire in a large, chambered firebox will not produce any heat in the components of the fireplace or in your room. Choose the fire that best suits your living and heating requirements.

### **Reloading your Kemlan fire -**

When it is time to add timber to your fireplace firstly make sure the underside of your white baffles is actually white, if they are still black this will mean the hardwood has not fully caught alight. If this is the case wait, you will notice as the fire heats up and your seasoned hardwood is fully lit the baffle plates will return to their original white condition, this means the fire drawing correctly through the flue system and burning cleanly with the secondary air in full swing.

You can now open the air slide fully, crack the door slightly allowing the air pressure to equal then carefully fully open the door.

Have the timber you are going to load in the chamber ready to immediately reload, be prepared, don't open the door and then go looking for the optimal pieces of timber, the longer you wait the colder the chamber will get and the higher the chance of smoke coming back into the room.

### **Overnight burns -**

All medium and large size Kemlan fireplaces have what is called an 'overnight burn' but what does this mean??

Like we have touched on above, the air slide should only be shut down fully when you want extended length of burn, as soon as you starve the firebox of air the fire will burn dirtier and heat output will be greatly reduced, in some instances the glass will blacken due to the lack of air movement inside the chamber. The black creosote will burn off the glass when the fire's air control is back up to high with a new load of timber.

Generally, a Kemlan medium to large chamber will burn between 8 - 12 hours depending on the quality of fuel/timber and how full you stack the chamber. For maximum burn time you would fill the chamber up to 50mm below the secondary air tubes underneath the white baffle plate. The larger the pieces of timber the better!

After the 8-12 hours you should still have glowing embers in the base of the fire, a small amount of kindling and medium size pieces of hardwood can then be re-loaded making sure the air control has been moved back to 'full left' introducing maximum primary air again.

If you follow these simple steps, you will find your Kemlan fireplace is one of the best investments you have made to your home.

From everyone in Kemlan we thank you for your business and wish you a lifetime of warmth and enjoyment.

### **IMPORTANT:**

**UNDER NO CIRCUMSTANCES SHOULD ANY SOLVENTS SUCH AS METHYLATED SPIRITS, PETROL, MINERAL TURPENTINE ETC OR DETERGENTS, BE ALLOWED TO COME IN CONTACT WITH THE PAINTED SURFACE OF THE HEATER AS DAMAGE TO THE FINISH WILL RESULT. IF AN ACCIDENT DOES OCCUR, SPRAY CAN PAINT IS AVAILABLE FROM YOUR NEAREST KEMLAN DEALER.**



# Certificate of Compliance for **SOLID FUEL HEATERS**

*This is to certify that the appliance stated on this certificate has been tested for Thermal Clearances, Heat Output, Thermal Efficiency and Particulate Emissions in accordance with the Australian / New Zealand Standard(s) detailed below*

|                                     |   |
|-------------------------------------|---|
| <i>Manufacturer</i>                 | <b>Kemlan Industries</b>  |
| <i>Make</i>                         | <b>Kemlan</b>   |
| <i>Model</i>                        | <b>Celestial 900</b>  |
| <i>Type</i>                         | <b>Insert/Inbuilt</b>   |
| <i>Category</i>                     | <b>Slow combustion Wood Heater</b>  |
| <i>Fuel Type</i>                    | <b>Softwood</b>   |
| <i>Test Report No:</i>              | <b>ASFT20012-1</b><br><b>ASFT19026-1, ASFT19081-1</b>                               |
| <i>Maximum Avg Heat Output</i>      | <b>6.7kW</b>  |
| <i>Overall Avg Efficiency</i>       | <b>68%</b>  |
| <i>Particulate Emissions Factor</i> | <b>1.5g/kg</b>  |
| <i>National Standards</i>           | <b>AS/NZS 4012 (2014)</b><br><b>AS/NZS 4013 (2014)</b><br><b>AS/NZS 2918 (2018)</b> |

*ASFT hereby grants to:*

## **Kemlan Industries**

of  
13 French Avenue, Brendale QLD, Australia, 4500

Certificate No.: **ASFT20C025**  
Issue Date: **27 March 2020**

Certified Date: **27 March 2020**  
Expiry Date: **8 August 2024**

*Steve Marland*

Managing Director of ASFT

ASFT is an accredited laboratory by the National Association of Testing Authorities (NATA accreditation No. 20042) for compliance with ISO/IEC 17025. ASFT performs compliance testing of Solid Fuel Appliances to the relevant Australian/New Zealand standards under this Accreditation. This activity is coupled with periodic surveillance of the certified product taken from the market place or the manufacturer's factory. This certification is subject to the conditions set forth in the characteristics below and is not to be construed as any recommendation, assurance or guarantee by ASFT of the product acceptance by Authorities having jurisdiction.

# INSTALLATION INSTRUCTIONS

## MINIMUM HEIGHT OF FLUE SYSTEM EXIT INSTALLATION TO COMPLY WITH AS/NZS 2918

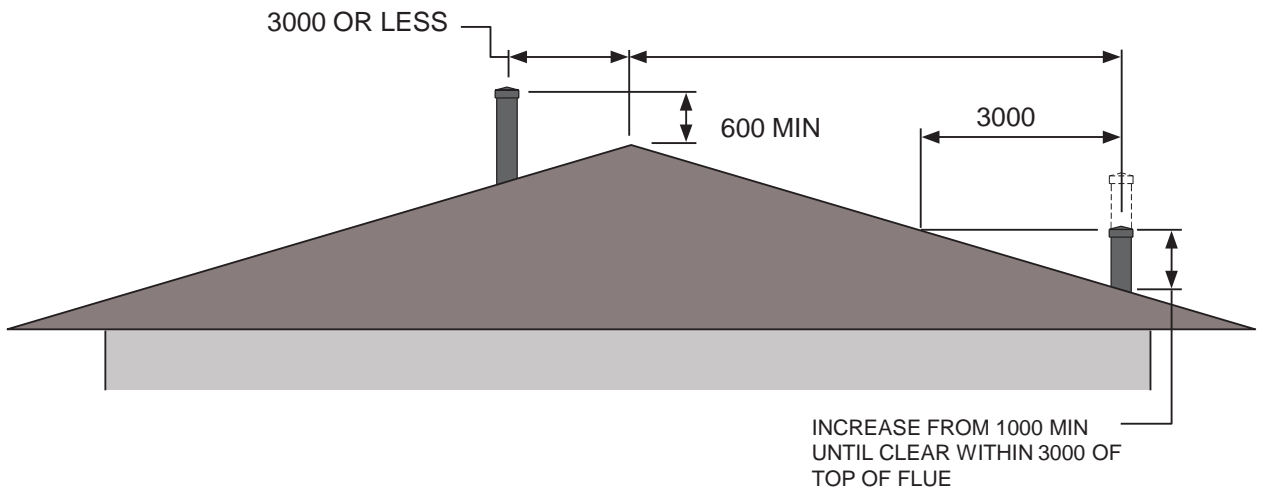
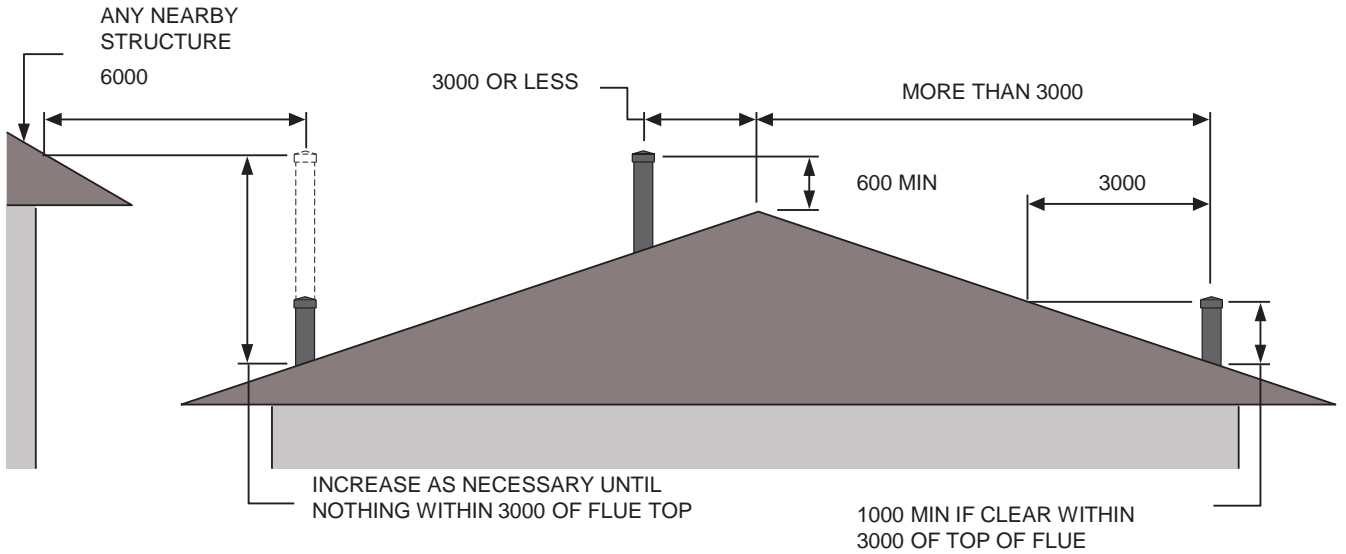

# WARRANTY

1. Kemlan wood heaters carry a warranty on the 6mm firebox for a period of ten (10) years.
2. This warranty also covers other components of the heater for a period of one (1) year. These components include the baffle plate, handle assembly, secondary air tubes and fan.
3. Kemlan's warranty covers the wood heaters against defects in materials and manufacture.

## 4. THIS WARRANTY DOES NOT COVER –

- 4.1 Failure to comply with manufacturer's operation instructions.
- 4.2 Normal wear and tear or damage caused by incorrect installation.
- 4.3 Any form of rust and/or corrosion to the painted finish of the heater.
- 4.4 Damage to the glass in the door, if the damage is caused by impact or misuse.
- 4.5 The cost of collection and delivery of the wood heater and/or parts.
- 4.6 Damage caused by water ingress.
- 4.7 Cost of removal of defective heater or re-installation of replacement heater.
- 4.8 Failure to use fireplace components supplied by Kemlan Industries Pty Ltd.
- 4.9 Cost of inspection for damaged heater.

## 5. CLAIMS –

- 5.1 (I) Kemlan will provide a full replacement of the heater in the first five years after installation.
  - (ii) Replacement in the subsequent five years (i.e. sixth to tenth year after installation will be on the following basis.  
Owner will pay fifty percent of the current retail price, if the claim is made in the sixth year – tenth year after purchase.
- 5.2 Replacement of heater subject to all conditions in section four of warranty.
- 5.3 Should any defects occur, contact the Kemlan distributor from whom you purchased the heater.
- 5.4 Under this warranty the defective parts will be repaired or replaced, free of charge.
6. The fireplace installation must comply with the relevant local statutes, ordinances, regulations and by-laws.

## 7. THIS WARRANTY IS VOID IF:

- 7.1 The appliance has been over-fired or operated in atmospheres contaminated by chlorine, fluorine or other damaging chemicals. Over-firing can be identified by, but not limited to, warped plates or tubes, rust coloured cast iron, bubbling, cracking and discolouration of steel or enamel finishes.

## PLEASE COMPLETE AND RETAIN THIS SECTION FOR YOUR RECORDS

Purchased from: .....  
Address: .....  
Date of Purchase: .....

# NOTES

---

---

---

---

---

---

---

---

---

---

---

---

---

---

---

---

---

---

---

---

---

---

---

---





